

INSTALLATION GUIDE



SAFETY

THE SAFETY OF YOU AND OTHERS IS VERY IMPORTANT TO US!

In order to minimize this risk and make an informed decision about safety, it is important that you carefully read and follow the installation instructions we have provided.

We urge you to use your own good judgment and allow plenty of time for install.

HAZARD CHECKLIST

- Always wear personal protective equipment (PPE) such as: protective eye wear, gloves, close toed shoes, etc.
- We recommend that you use a certified mechanic or shop for professional installation.
- Always set emergency brakes on vehicle and use tire blocks to ensure vehicle stabilization.
- Use caution when lifting, we recommend the use of equipment to help lift bumpers into place.
- Use caution when using power tools such as air ratchet, etc.
- Take caution when installing wiring.
- Perform regular inspections of hardware, bolts, brackets, etc.
- Rigid light brackets are specifically designed to fit Rigid lights, we do not guarantee off brand fitment.
- Our winch mount is designed for Warn and Superwinch products. We do not guarantee off brand fitment.

USE & RISK

- **Bodyguard Products LLC is not responsible for damage to our products, or other subsequent damage that might occur, as a result of misuse or improper installation. While we do manufacture products that appear stronger than factory parts, our products should not be viewed or relied upon as life-saving devices in the event of a collision or rollover. We make no claims relating to airbag compatibility, crashworthiness, or sturdiness. It is the customer's responsibility to check with the vehicle manufacturer or auto dealer regarding airbag compatibility and automobile manufacturer's warranty before installing our products.** Use either foam or tape on fenders to prevent scratches to the truck when installing your bumper.

PREPARATION

- Ensure personal safety by checking for hazards and identifying risks.
- Check for correct hardware.
- Check for tools needed.
- Use either foam or tape on fenders to prevent scratches to the truck when installing your bumper.
- Please allow approximately 3-4 hours for installation.
- Disconnect the battery.

- Please allow approximately 3-4 hours for installation.

NOTE: IF A WINCH IS INSTALLED WITH FAIRLEAD, AND A LICENSE PLATE IS REQUIRED; AN AFTERMARKET FAIRLEAD MOUNTED LICENSE PLATE BRACKET MAY BE NEEDED.

- This bumper is designed to mount either a light bar OR winch.

I. HARDWARE KIT

07+ Jeep Universal Front Mount Kit	Qty.
1/2"-13 x 1-1/2" Stainless Steel Hex Bolt	8
1/2" Stainless Steel Flat Washer	10
1/2" Washer, Grade 8 Zinc-Yellow	8
1/2"-13 Grade 8 Steel Serrated Flange Nut Zinc	10
1/4-20 x 5/8 Long, Stainless Steel SBHCS	29
1/4-20 (.093-.126: Panel Range) Zinc Electroplate Spring Steel Cage Nut	27
1/4-20 Hex Grade 5 Serrated Flange Nut, Stainless Steel	4
3/8"-16 x 1" Yellow Zinc Grade 8 Hex Bolt	6
3/8" Yellow Zinc Grade 8 Flat Washer	12
3/8"-16 Zinc Grade 8 Serrated Hex Flange Nut	6
1/2" x 1 1/2" Tear Drop Bolt	2
07+ A2 Jeep Front Stubby Plate Kit	Qty.
1/4-20 x 5/8 Long, Stainless Steel SBHCS	9
1/4-20 (.093-.126: Panel Range) Zinc Electroplate Spring Steel Cage Nut	9
07+ A2 Jeep Baja Bar Kit	Qty.
5/16"-18 x 3/4" Long, Stainless Steel SBHCS	8
5/16" Zinc Grade 5 Flat Washer	16
5/16"-18 Zinc Grade 8 Serrated Hex Flange Nut	8

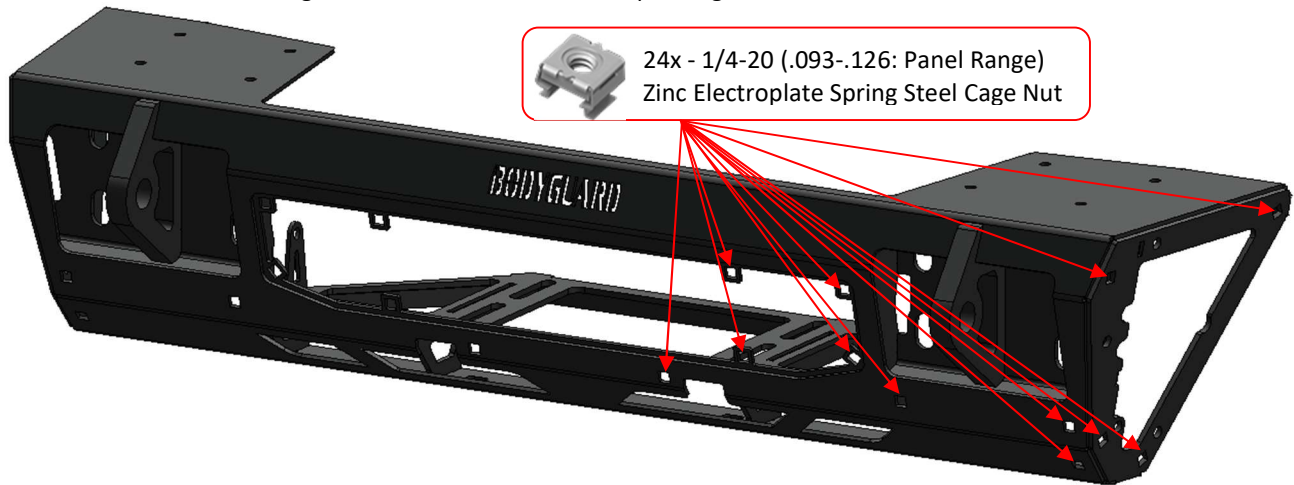

II. CAGE NUT INSTALL

1. Install supplied cage nuts into the square cutouts on the bumper. This will assist in installing all bolt on plates. All cage nuts will face the inside of the bumper. The below image only has arrows pointing out the driver side but you will install the cage nuts on both the driver and passenger side.





III. BAJA BAR INSTALLATION

1. Install the Baja Bar onto your bumper first. You will not be able to access these bolts once the bumper is installed.

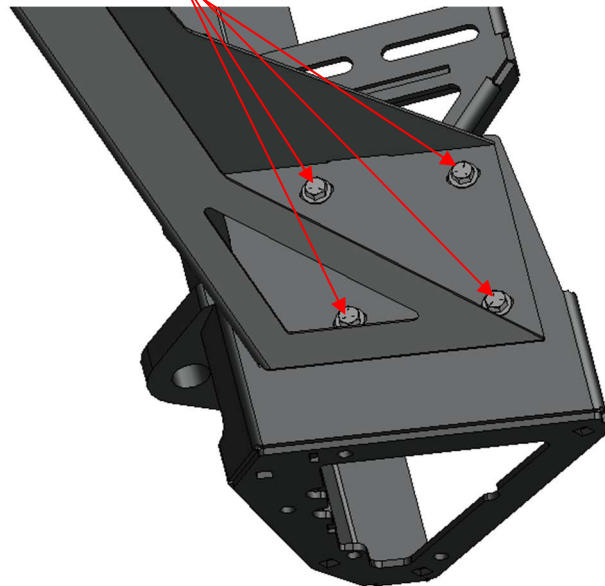
-  8x - 5/16"-16 x 1" Yellow Zinc Grade 8 Hex Bolt
-  16x - 5/16" Yellow Zinc Grade 8 Flat Washer
-  8x - 5/16"-16 Zinc Grade 8 Serrated Hex Flange Nut



2. Install the light bar mesh onto the Baja Bar.

-  2x - 1/4-20 x 5/8 Long, Stainless Steel SBHCS
-  2x - 1/4-20 (.093-.126: Panel Range) Zinc Electroplate Spring Steel Cage Nut

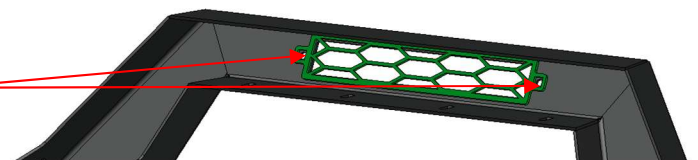

3. Install the light bar tabs onto the Baja Bar. Then install your 10" single row light bar to these tabs



2x - 1/4-20 x 5/8 Long, Stainless Steel SBHCS



2x - 1/4-20 Hex Grade 5 Serrated Flange Nut, Stainless Steel



IV. WINCH OPTION INSTALL

1. Install the winch into the bumper using the slots marked below. Do not tighten winch all the way down. When installing the bumper some winches will have to be moved forward or back to fit between frame rails.
NOTE: Some winches cannot be installed after the bumper has been installed.

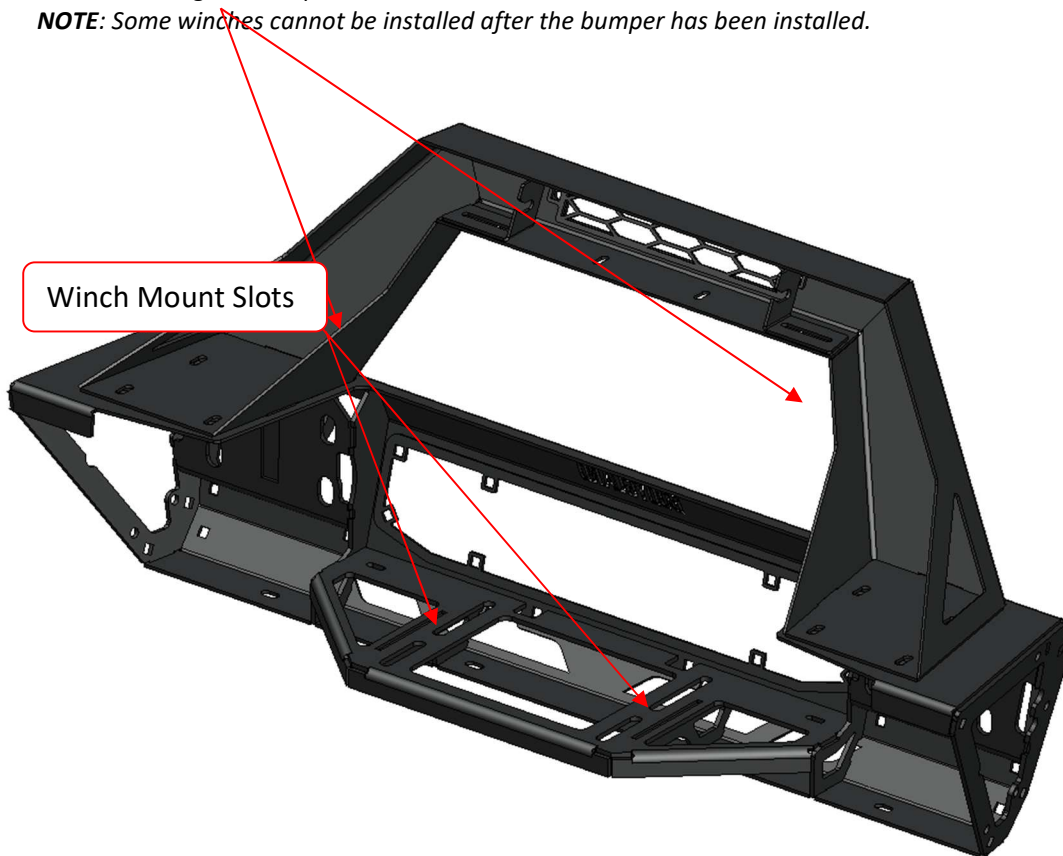

3. Install the winch cover plate.

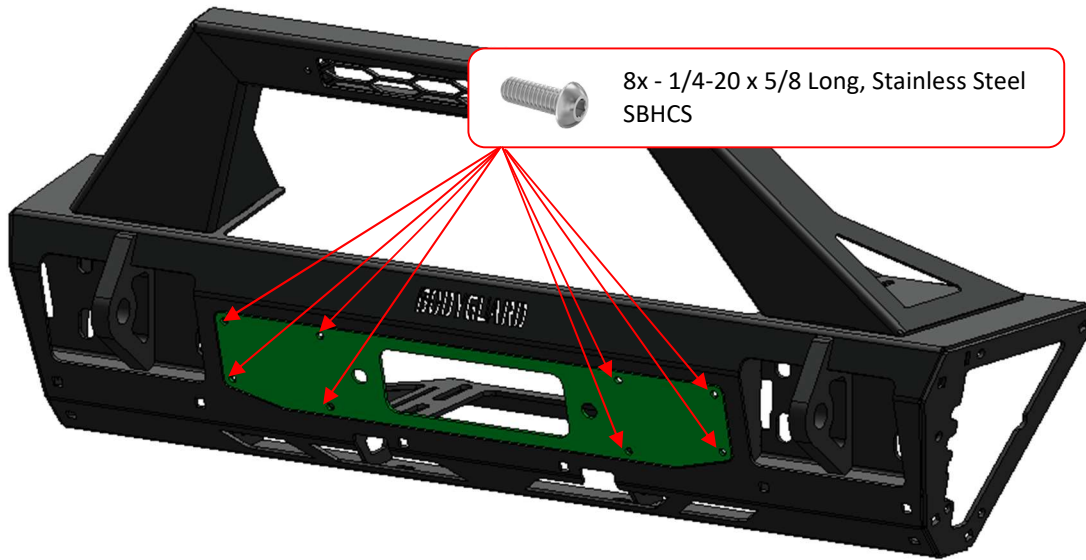

4. After you install the winch cover plate you can install your fairlead to the winch cover plate.

V. BUMPER INSTALL

1. Install the bumper onto the frame. We provide eight stainless steel washers that will be used for the outside face of the bumper as shown in the image below. The yellow zinc washers will be used on the inside.

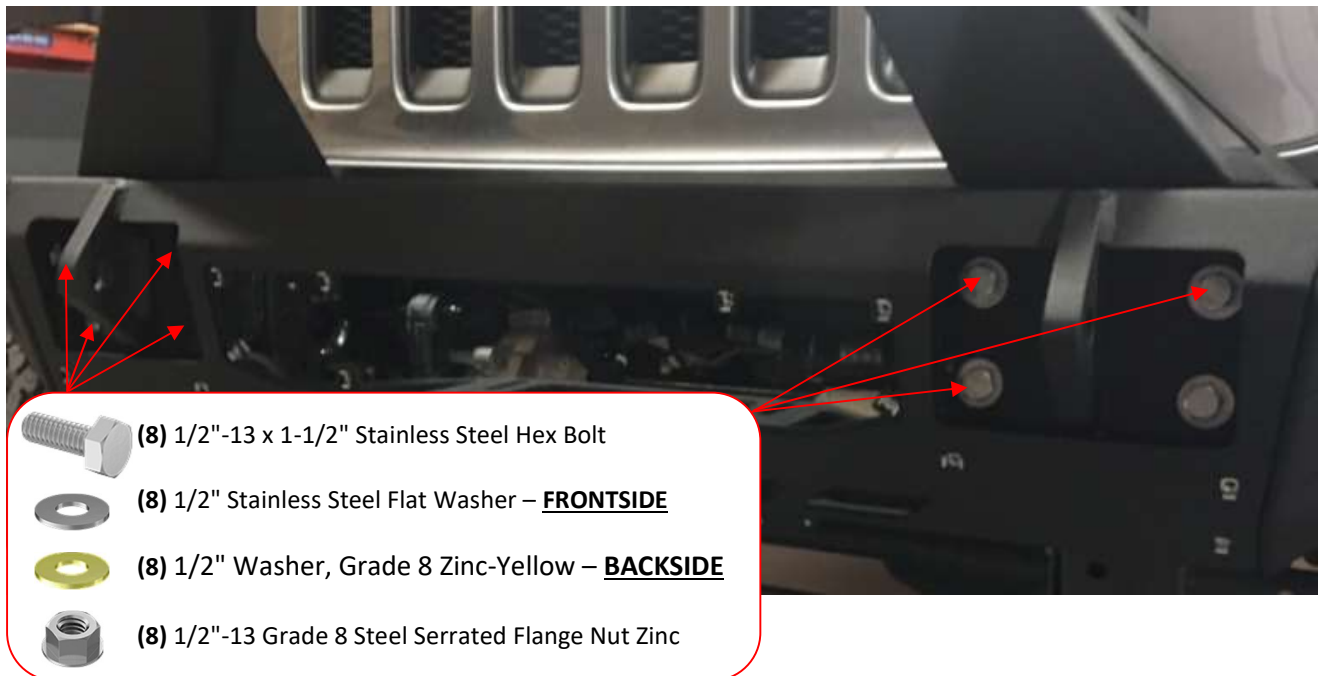

VI. STUBBY END PLATES

1. Install the end plates onto the driver and passenger sides of the bumper. The bolts will bolt through this plate and be secured by the cage nuts that were installed in **Step II**

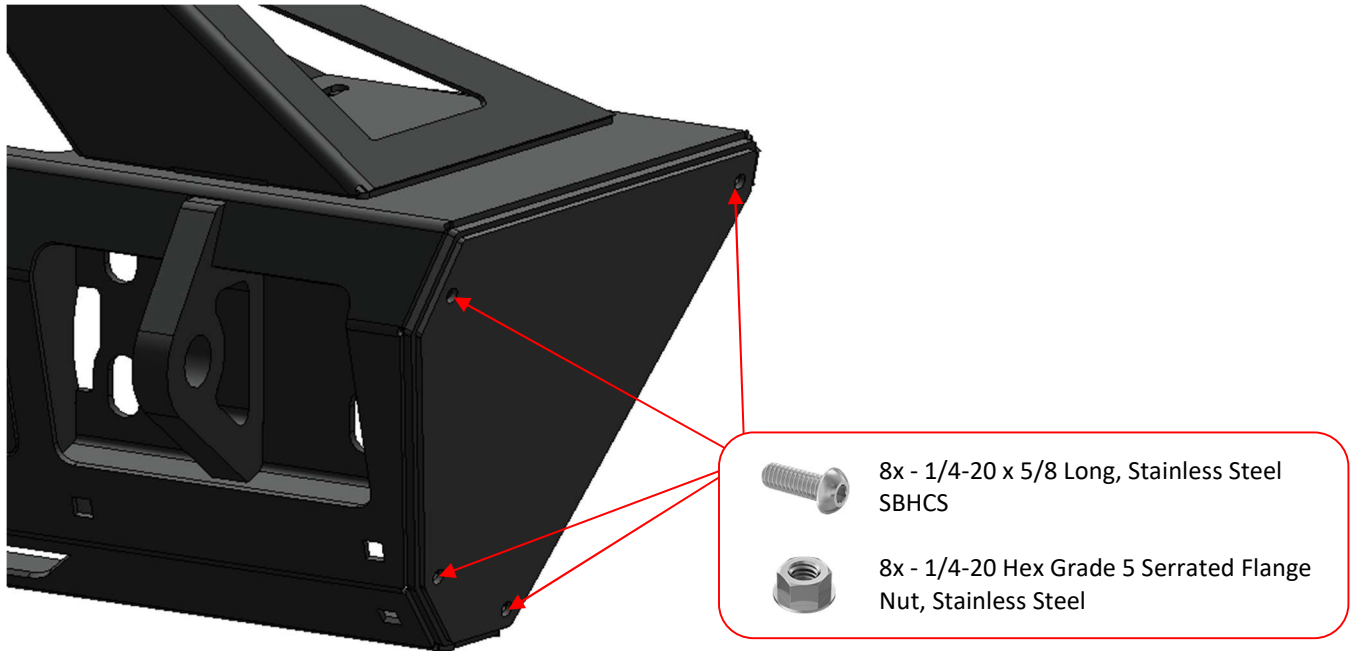

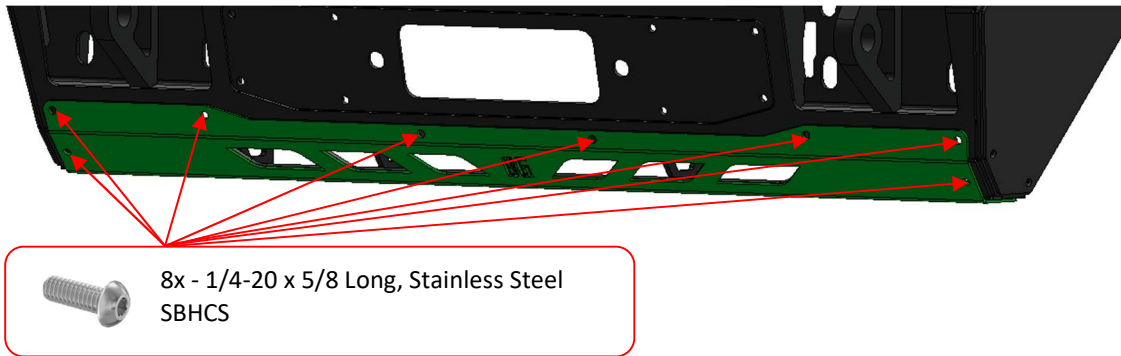

VII. SKID PLATE INSTALLATION

1. Install the BG skid plate onto the bumper. The bolts will bolt through this plate and be secured by the cage nuts that were installed in **Step II**







2. Next install the skid plate bracket to the crossmember by inserting a teardrop bolt into the frame. Do this before installing the skid plate.

-  (2) 1/2" x 1 1/2" Tear Drop Bolt
-  (2) 1/2" Yellow Zinc Grade 8 Flat Washer
-  (2) 1/2"-13 Zinc Grade 8 Serrated Hex Flange Nut

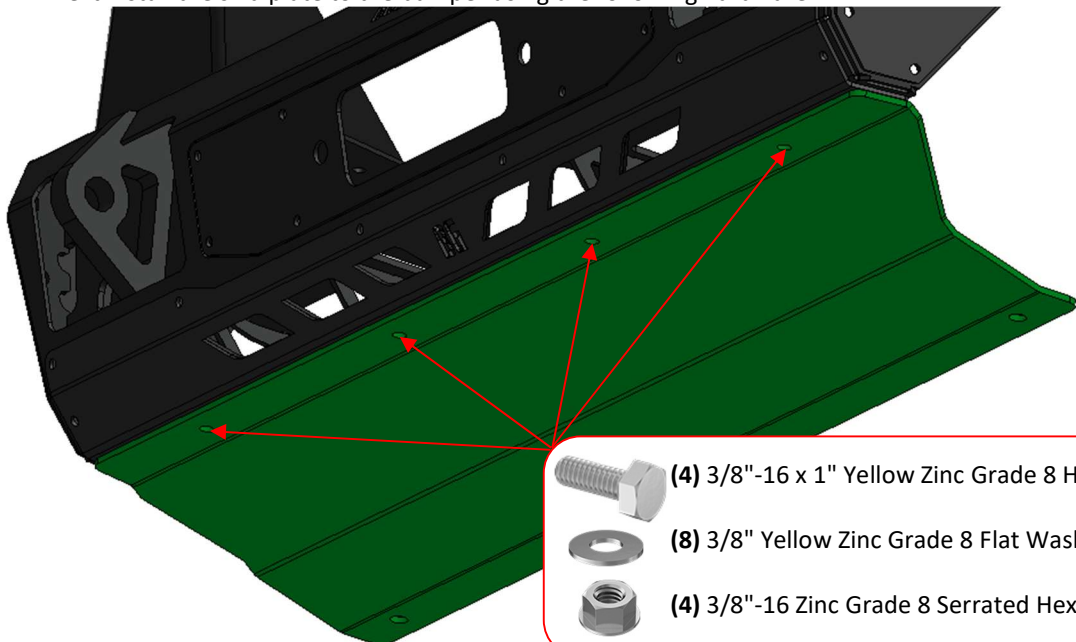

3. Next install the skid plate to the bumper using the following hardware.



-  (4) 3/8"-16 x 1" Yellow Zinc Grade 8 Hex Bolt
-  (8) 3/8" Yellow Zinc Grade 8 Flat Washer
-  (4) 3/8"-16 Zinc Grade 8 Serrated Hex Flange Nut

4. Then install the skid plate to the skid plate brackets that were installed on step 2.

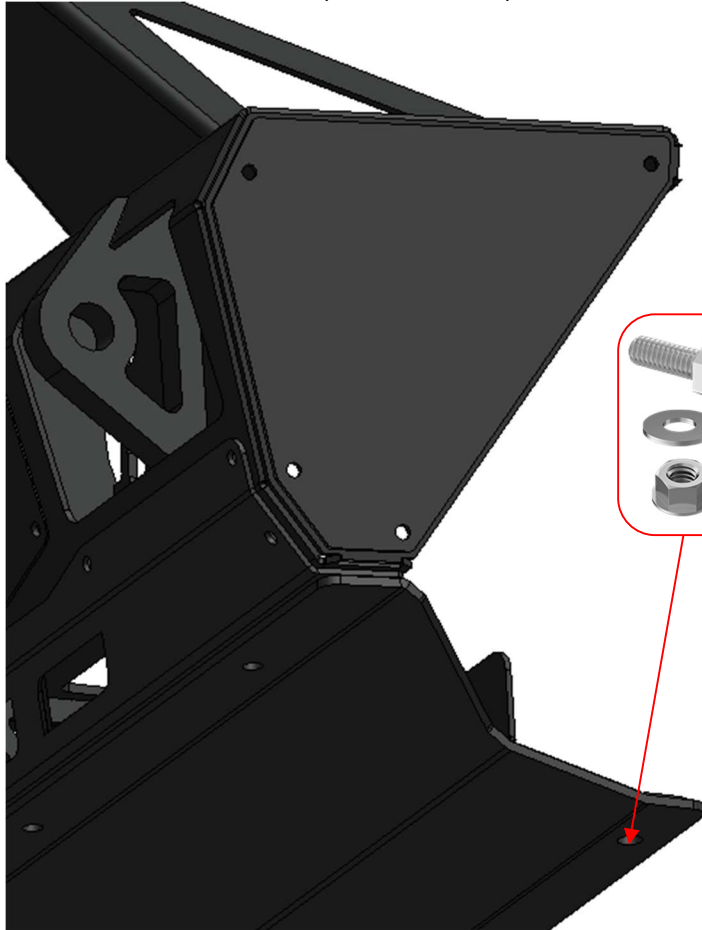

(2) 3/8"-16 x 1" Yellow Zinc Grade 8 Hex Bolt



(4) 3/8" Yellow Zinc Grade 8 Flat Washer



(2) 3/8"-16 Zinc Grade 8 Serrated Hex Flange Nut

FINISHING UP

- Install shackles.
- Confirm that all hardware is tightened and everything is secure.
- Secure wiring harnesses for lights and sensors.
- Reconnect the battery.
- Test all lighting and wiring before using vehicle (fog lights, sensors, etc.).

MAINTENANCE

- Periodically check that all hardware is tightened and that all wiring and connections are secure.
- Periodically check that all sensor plugs are secure.
- Routinely wash bumper to maintain the powder coat finish.

FEEDBACK

We'd love to hear from you!

Please send your pictures, testimonials, comments, or suggestions to us by email at info@bodyguardbumpers.com. We frequently use customer pictures for brochures and marketing materials, and we always welcome customer feedback to ensure quality improvements within our company. Thanks for your purchase; we appreciate your business very much!

Where **STRENGTH** Meets *Style!*™



@BodyguardBumpers